

EXCEPT AS OTHERWISE PROVIDED BY CONTRACT, THIS DRAWING AND SPECIFICATIONS SHALL NOT BE REPRODUCED, COPIED OR USED AS THE BASIS FOR MANUFACTURE OR SALE OF MATTER DEPICTED HEREIN WITHOUT THE EXPRESSED WRITTEN PERMISSION OF THE CLAUDE LAVAL CORPORATION, OR ITS ASSIGNEES.

THIS DRAWING HAS BEEN GENERATED AND IS MAINTAINED BY A CAD SYSTEM. CHANGES SHALL ONLY BE INCORPORATED AS DIRECTED BY AN APPROVED ENGINEERING CHANGE ORDER (ECO). PAPER COPIES ARE UNCONTROLLED.

REVISIONS				
ECN	REV.	DESCRIPTION	DATE	APPROVED

NOTES:

1. INLET IS 3" PIPE (125# ANSI FLANGED).
2. OUTLET IS 2" PIPE (GROOVED).
3. PURGE OUTLET IS 1-1/2" PIPE.
4. MAXIMUM PRESSURE: 150 psi (10.3 bar).
5. MAXIMUM TEMPERATURE: 122°F (50°C).
6. SPECIFIED FLOWRATE OF 100 gpm (23 m³/hr).
7. FINISH: AS ASSEMBLED.
8. POWER REQUIREMENT: 415V, 3PH, 50Hz.
9. NEMA 4X MOTOR STARTER ENCLOSURE WITH SAFETY DISCONNECT AND H.O.A. SWITCH.
10. APPROXIMATE DRY WEIGHT: 1370 lbs (621 kg).
11. INLET/OUTLET VALVE KIT, MODEL TCX-0100 RECOMMENDED.
12. MINIMUM PIPE FROM TOWER BASIN TO JC SYSTEM IS 3" PIPE.
13. FLOODED SUCTION REQUIRED.
14. LIFTING LUGS NOT SUPPLIED.

COMPONENT LIST:

- ① ELECTRICAL CONTROL BOX 415 50Hz W/120V TRANSFORMER WITH RUN LIGHTS & BAG FULL LIGHT.
- ② SEPARATOR: JPX-0060/V.
- ③ PUMP: 7.5 HP CENTRIFUGAL, 1500 rpm, 415V, 50Hz, PREMIUM EFFICIENCY, 50°C.
- ④ INLET/OUTLET PRESSURE GAUGES: 0-100 psi, GLYCERIN-FILLED.
- ⑤ PURGE EQUIPMENT: SRV-816.
- ⑥ DIFFERENTIAL PRESSURE INDICATOR W/DRY CONTACT-MODEL DHE-15-S.
- ⑦ BASKET STRAINER.

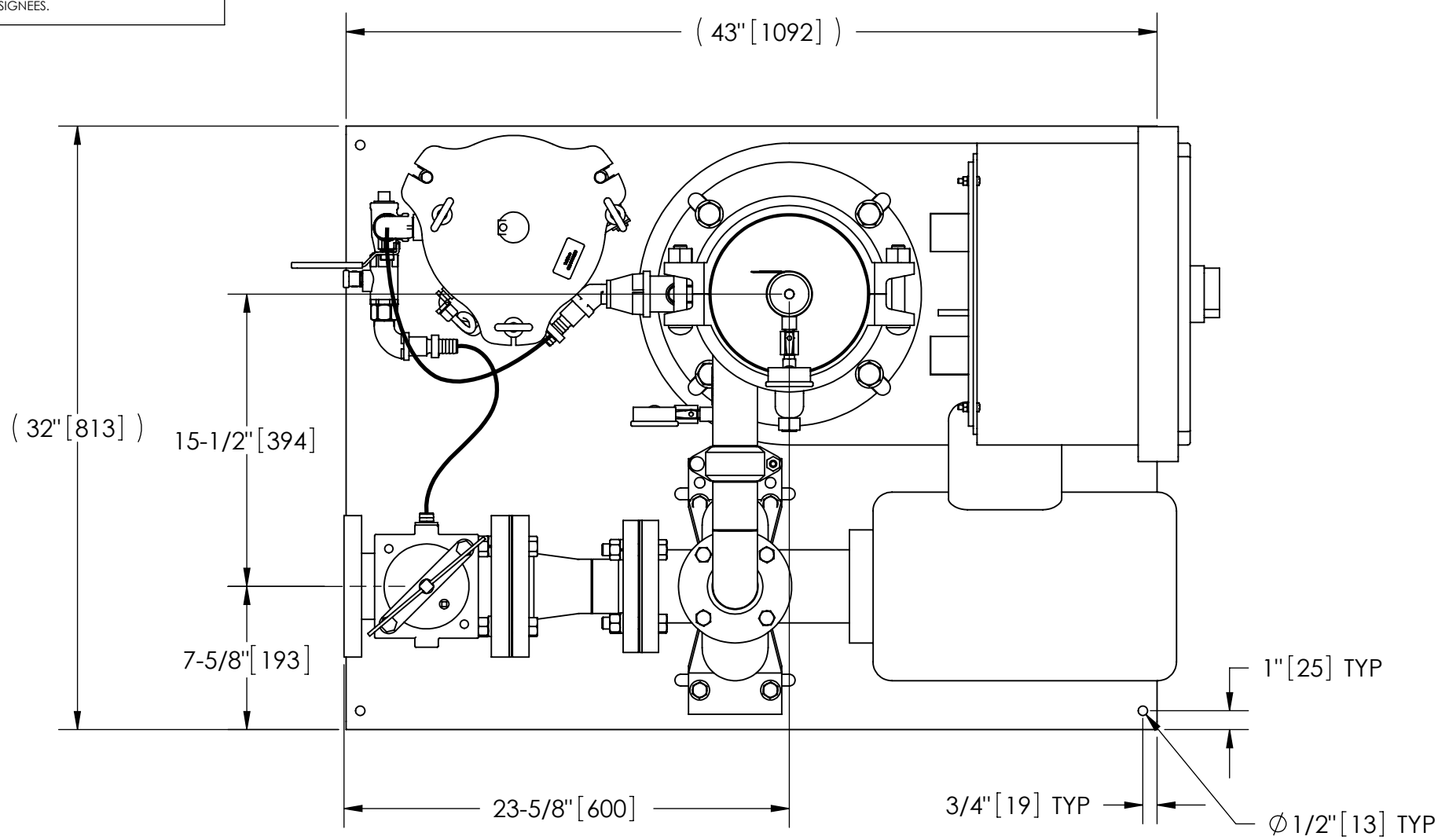

TOP VIEW

SUBMITTAL DRAWING

This drawing is submitted for spatial consideration only. Do not pre-plumb to these dimensions.

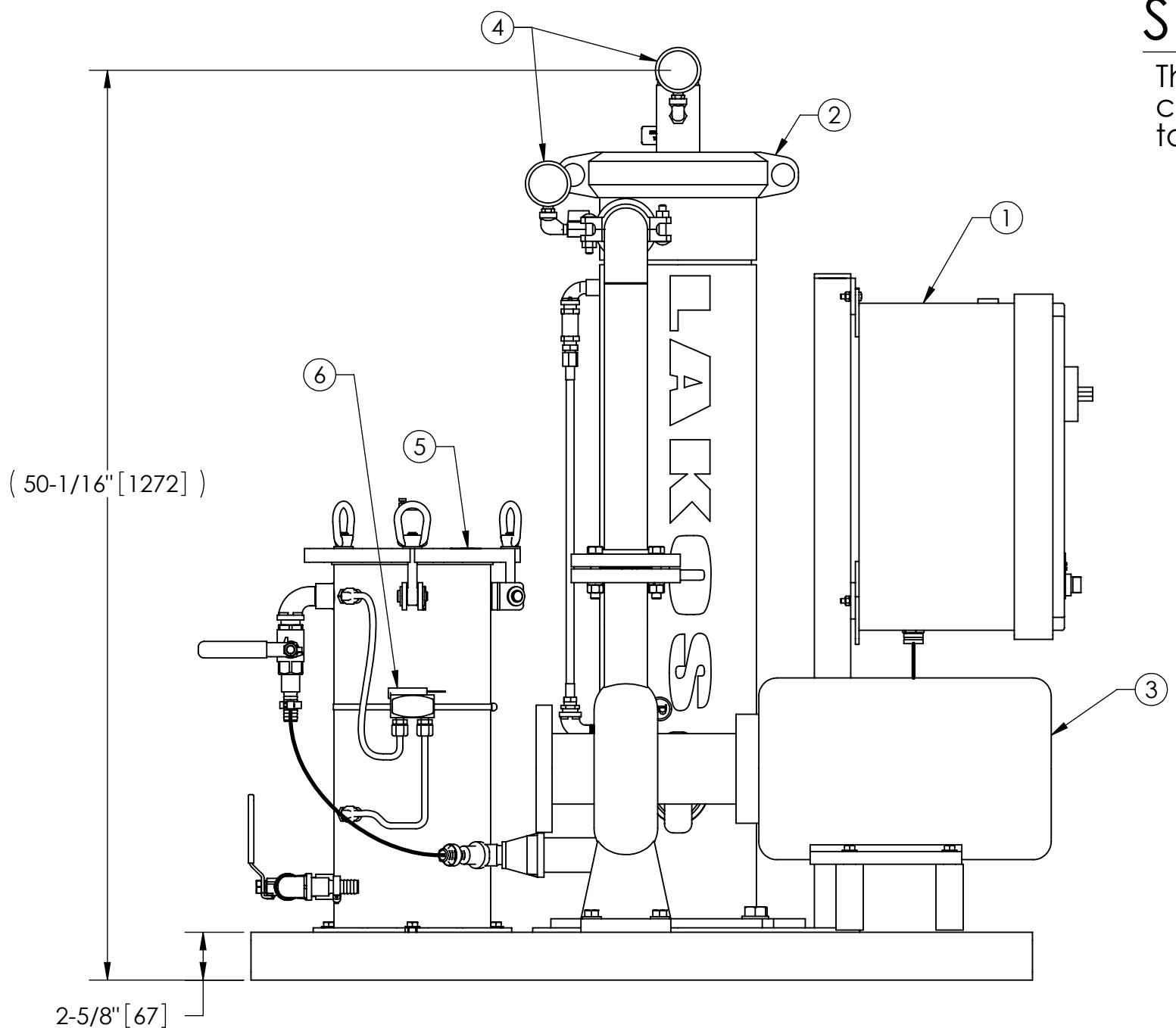

FRONT VIEW W/O STRAINER

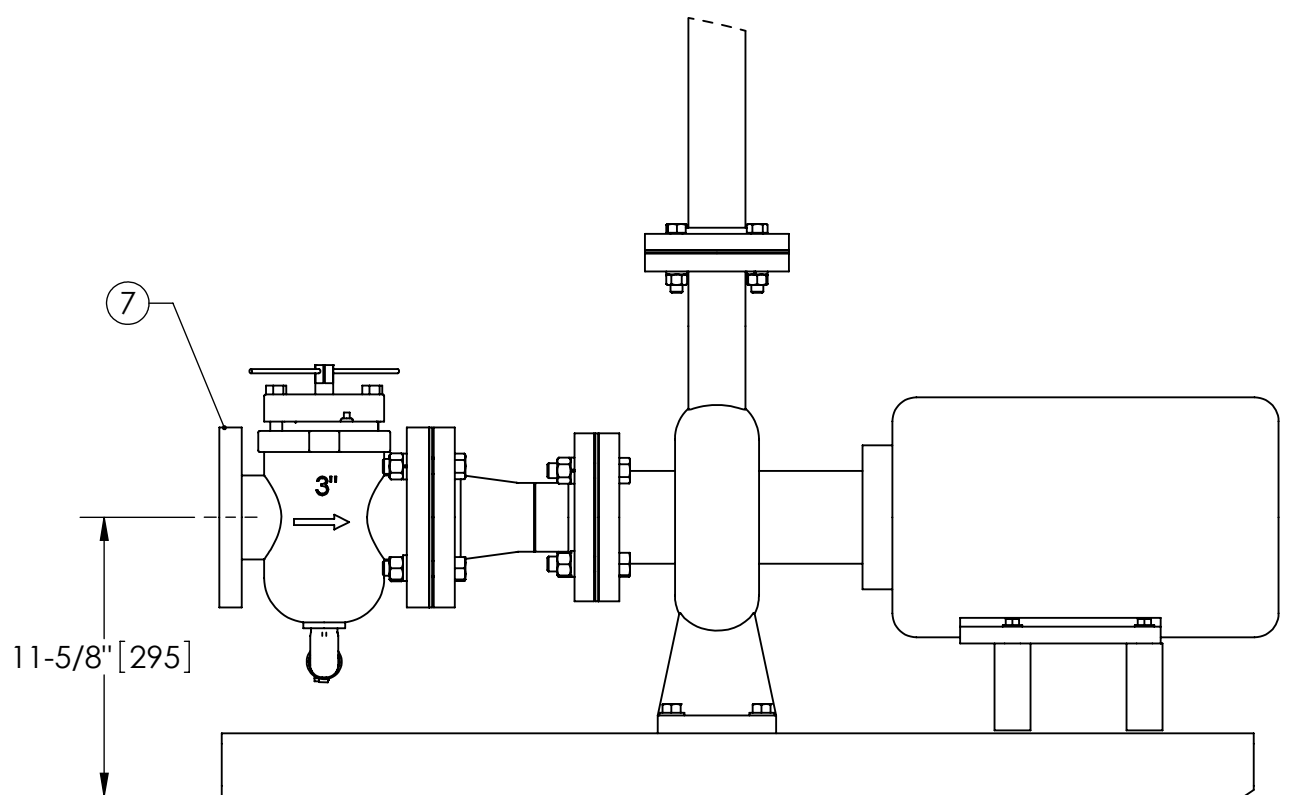

FRONT VIEW PUMP & STRAINER

UNLESS OTHERWISE SPECIFIED: DIMENSIONS ARE IN: INCHES (mm) TOLERANCES ARE: FRACTIONS .XX ± .01 DECIMALS .XXX ± .005 ANGLES ± 1/4° ± 1" ± .005	ENGINEERED FOR: 415V / 50°C	CLAUDE LAVAL CORP. FRESNO, CALIFORNIA 93727 WWW.LAKOS.COM	LAVAL UNDERGROUND SURVEYS	
	APPROVALS			DATE
	DRAWN CAG			3/30/11
	ENGR -			-
DO NOT SCALE DRAWING	MATERIAL PER LAKOS SPEC	TITLE JCX-0100-SRV/415V/50C, JC SYSTEM SWEEPER JPX-0060, 415V 50HZ DELUXE 50C		
FINISH AS ASSEMBLED	MFG -	SIZE C	MODEL NO.	
	WORK ORDER	DWG NO. 132837	REV. 01	
		SCALE 1:8	EST. WT. 1370 lb	SHEET 1 OF 1

DWG. NO. 132837 SHEET 1 REV. 01