

Solids Recovery Vessel

Capture Separated Solids with Zero Liquid Loss



SRV-833

SRV-816

SRV shown with optional SRI package and manual ball valves

Solids Recovery Vessel (SRV) Package:

Retention Vessel: 304 Stainless Steel construction with epoxy-coated carbon steel lid

Internal Baskets: One (1) Stainless Steel basket

Filter Bags: Two (2) polyester-felt bags

Air Relief Valve: One (1) 1/4" float vent valve

Available Sizes:

SRV-816 includes two (2) 25 micron bags*

SRV-833 includes two (2) 10 micron bags

*Optional 50 micron bag may be specified

Note: Manual valves for isolation are required, but not included in the package

Standard Configurations:

Model	Internal Basket and Collection Bag Height		Microns*	
	14" Basket with 16" Bag	28.5" Basket with 33" Bag	25µm/50µm	10µm
SRV-816	✓		✓	
SRV-833		✓		✓

* Collection bags for SRV-816 and SRV-833 are available in filter sizes starting at 1µm.

SRV Features and Benefits:

- Capture separated solids easily and return clean liquid back to system; resulting in zero liquid loss
- Continuous operation, remove captured solids without interrupting system flow or filtration
- Available in two sizes: SRV-816 (16 inches/406.4 mm) and SRV-833 (33 inches/838.2 mm)
- SRV-833 features double the surface area – providing for double the collection capacity and less frequent bag change-outs
- SRV-833 provides greater flexibility with using either a SRV-833 Basket and Bag or a SRV-816 Basket and Bag – if the weight of a collected bag is a concern
- Filter bags available from 10 microns to 50 microns
- Optional indicator package provides convenient way to determine bag change-outs
- Optional dry contact available for remote monitoring, can be tied to BMS (Building Management System)
- Lower waste water treatment costs, meet waste disposal requirements and greatly reduce chemical loss

SEPARATOR OUTLET

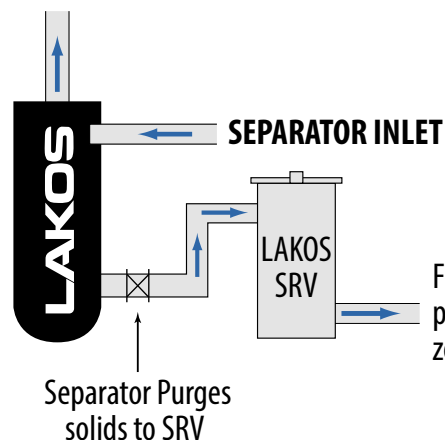

Solids Recovery Vessel (SRV) helps capture separated solids from LAKOS Separators – and return clean liquid back to the system through pump suction for zero liquid loss

Filtered water to pump suction for zero liquid loss

Models & Dimensions

Dimensions:

Model	Vessel Height "A"	Bag Height "B"	Bag Width "C"	Basket Height "D"
SRV-816	24-9/16" (624 mm)	16" (406 mm)	7" (178 mm)	14" (356 mm)
SRV-833	38-9/16" (979 mm)	33" (838 mm)	7" (178 mm)	28-1/2" (724 mm)

Specifications:

Maximum Pressure: 150 psi/10.3 bar

Maximum Operating Temperature: 122° F (50° C)

Model	Solids Collection Capacity	Liquid Retention Capacity	Total System Weight (without liquid)
SRV-816	360 cubic inches	5.0 gallons	54 lbs
	6 liters	19.0 liters	24.5 kg
SRV-833	732 cubic inches	8.0 gallons	74 lbs
	12 liters	30.5 liters	33.6 kg

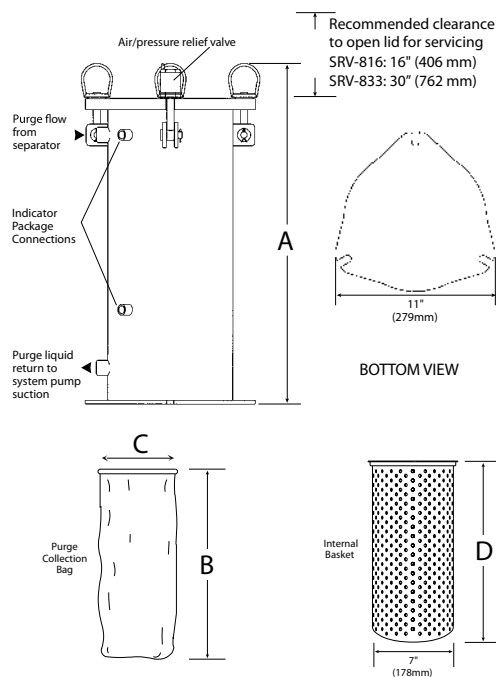

Optional Indicator Package SRI-816:

The optional SRI-816 package applies to both SRV-816 and SRV-833. It helps determine when bag change-out is necessary. The optional Indicator Package is responsive to increased pressure differential as the vessel accumulates with purged solids. This assembly identifies when the solids collection bag is full, minimizing routine servicing.

1 Ball Valves: Two (2) per package; 3/4-inch (female, N.P.T.) manual; bronze body¹, stainless steel ball, sealant seat

2 Annunciator: One (1) per package; 1/8-inch (female, N.P.T.) parts; "pressure indicator" style²

Annunciator is pre-set by LAKOS at a prescribed pressure differential of 1.5 psi (1 bar).

3 Flow Control Orifice: One (1) per package; 3/4-inch (female, N.P.T.);

bronze¹ rated for 10 U.S. gpm (2.3 m³/hr) but other sizes available

4 Clamp: Stainless steel band with hardware to mount annunciator to body of LAKOS Solids Recovery Vessel

5 Tubing: To hook up high/low pressure connections on annunciator;

1/4-inch diameter poly tubing for 150 psi

(10.3 bar) or less; water use only; 6 feet

(1.8m). End connectors also provided

6 Hose Connections: 3/4-inch, barbed x male thread connections

7 Hose: Reinforced rubber, 3/4-inch

¹Also available in stainless steel. Consult LAKOS for any special application requirements.

²Optional dry contact (DEC-100) is available to operate a 12 W light; 125/250 VAC-28 VDC, 2 amp. (Voltage booster relay available to activate buzzer or other indicator device or connect to BMS to trigger low level alarm when bag must be changed).

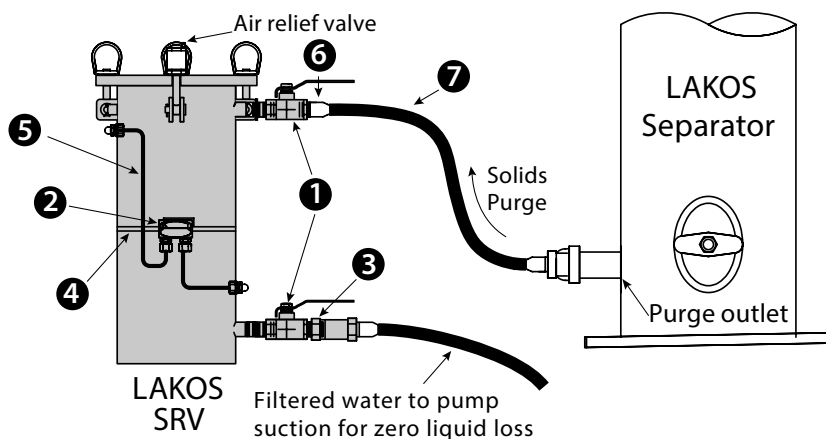

Claude Laval Corporation, headquartered in Fresno California since 1972, is recognized worldwide for engineering, manufacturing and marketing the original centrifugal action solids from liquids separator and being the world-wide leader in cyclonic separation technology.

LAKOS Separators are manufactured in the USA.

LAKOS is an active member of the U.S. Green Building Council
LAKOS is a proud and contributing member of ASHRAE for over 30 years

LAKOS® is a trademark of Claude Laval Corporation.

LS-622M (Rev. 6/17)



1365 North Clovis Avenue
Fresno, CA 93727

www.lakos.com

Tel: (595) 255-1601
info@lakos.com