

EXCEPT AS OTHERWISE PROVIDED BY CONTRACT, THIS DRAWING AND SPECIFICATIONS SHALL NOT BE REPRODUCED, COPIED OR USED AS THE BASIS FOR MANUFACTURE OR SALE OF MATTER DEPICTED HEREIN WITHOUT THE EXPRESSED WRITTEN PERMISSION OF THE CLAUDE LAVAL CORPORATION, OR ITS ASSIGNEES.

REVISION HISTORY				
ZONE	REV	DESCRIPTION	DATE	APPROVED

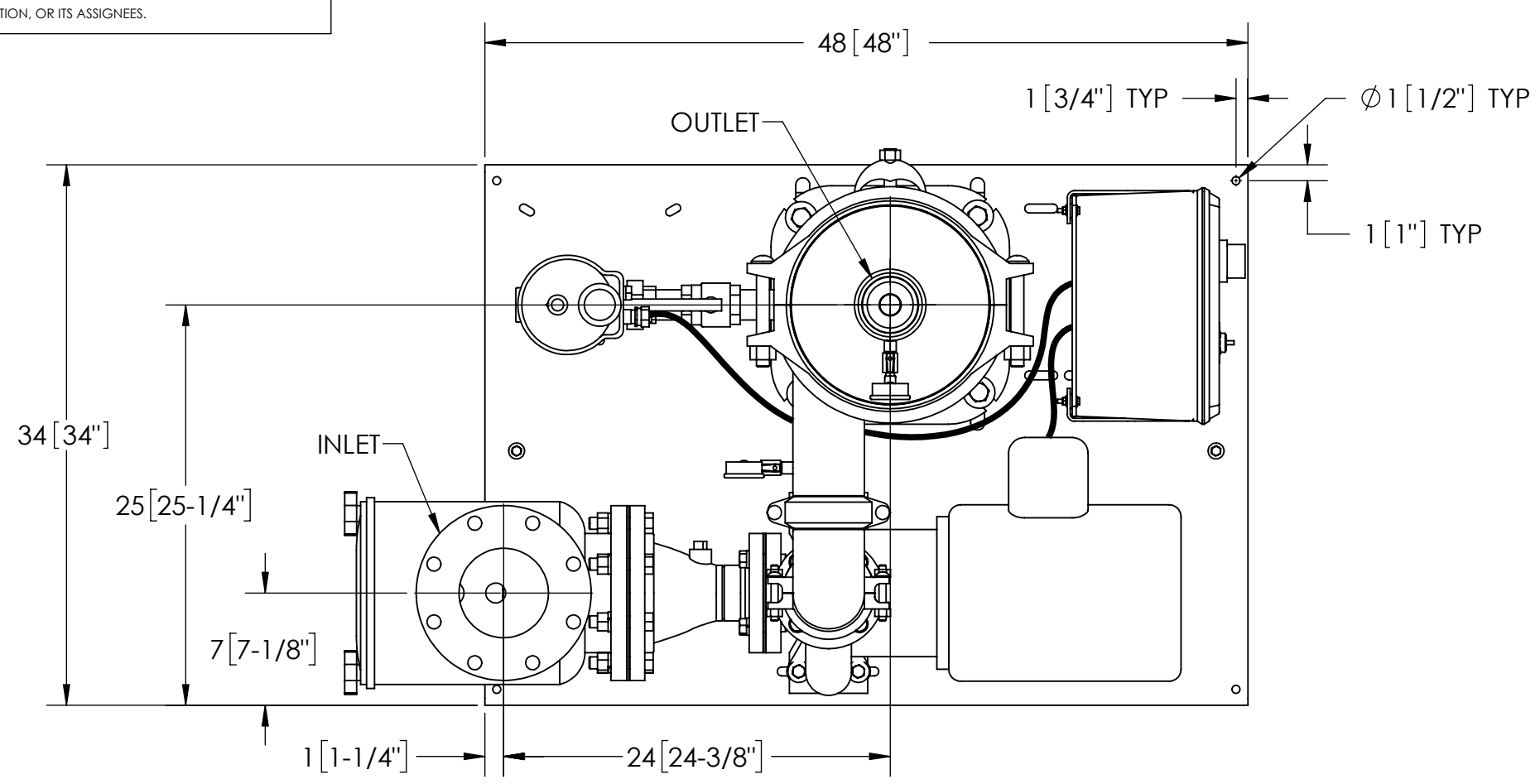

TOP VIEW

SUBMITTAL DRAWING

This drawing is submitted for spatial consideration only. Do not pre-plumb to these dimensions.

- NOTES:**
1. INLET IS 6" FLANGED (125# ANSI).
 2. OUTLET IS 4" PIPE (GROOVED).
 3. PURGE OUTLET IS 1-1/2" PIPE.
 4. MAXIMUM PRESSURE: 10.3 bar (150 psi).
 5. MAX FLUID OPERATING TEMPERATURE: 37.8°C (100° F).
 6. SPECIFIED FLOW RATES:
 BASIN SWEEPING- 70 m³/hr (310 gpm).
 SIDE STREAM & CLOSED LOOP- 83 m³/hr (365 gpm)
 7. FINISH: AS ASSEMBLED.
 8. POWER REQUIREMENT: 3/60/20/-230/460V. (CUSTOMER SPECIFIED)
 9. NEMA 4X MOTOR STARTER ENCLOSURE WITH SAFETY DISCONNECT AND H.O.A. SWITCH.
 10. APPROXIMATE DRY WEIGHT: 1161 kg (1358 lb).
 11. INLET/OUTLET VALVE KIT RECOMMENDED: SEE FACTORY.
 12. MINIMUM PIPE FROM TOWER BASIN TO TC SYSTEM IS 6" PIPE.
 13. FLOODED SUCTION REQUIRED.

COMPONENT LIST:

- ① ELECTRICAL CONTROL BOX 3/60/208-230/460V/120V TRANSFORMER.
- ② SEPARATOR: eHTX-0140-V.
- ③ PUMP: 7.5 HP CENTRIFUGAL, 1800 rpm, 3/60/208-230-460V.
- ④ INLET/OUTLET PRESSURE GAUGES: 0-100 psi, GLYCERIN-FILLED.
- ⑤ PURGE EQUIPMENT: EFS-15-120V.
- ⑥ STRAINER.

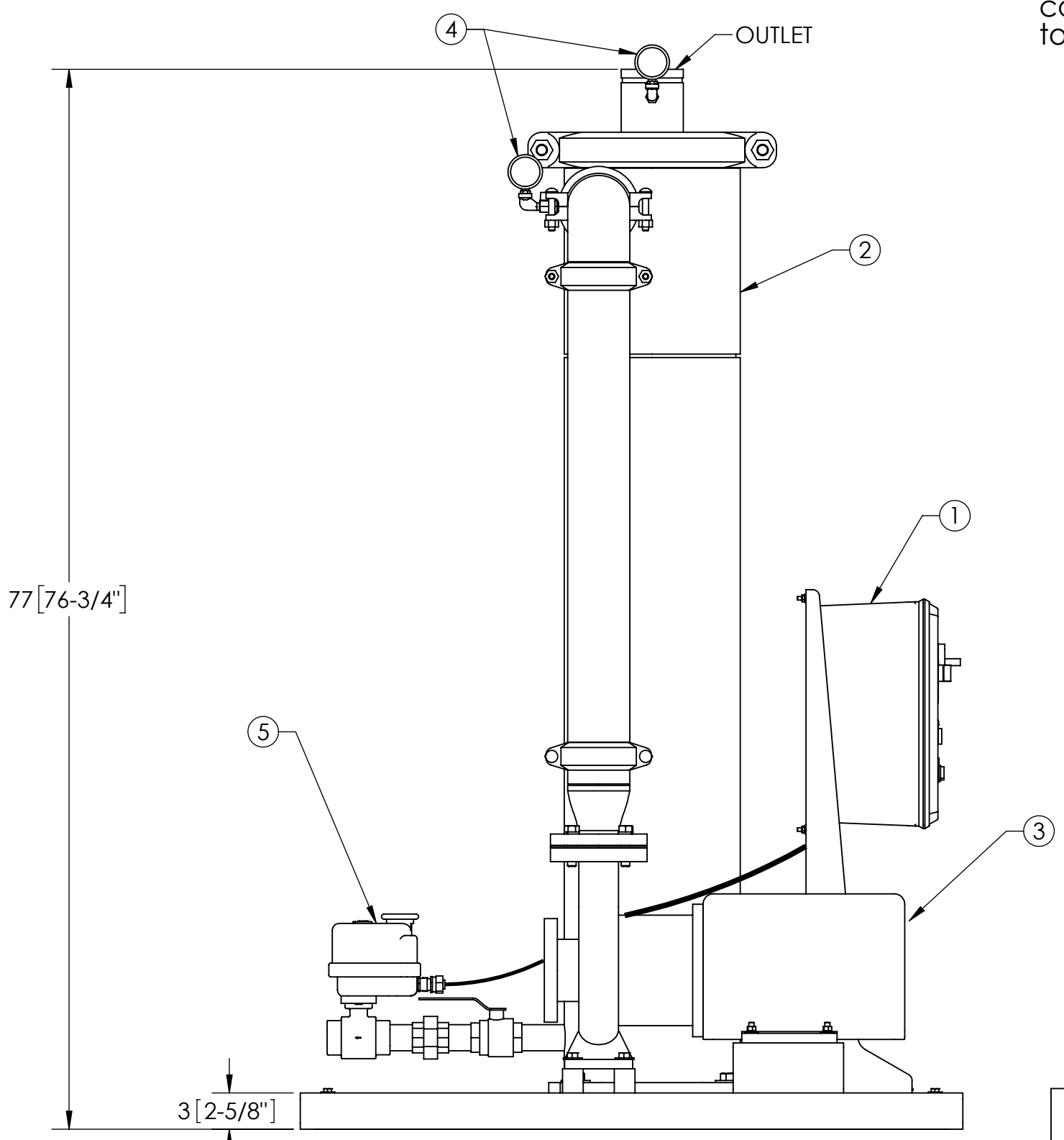

FRONT VIEW W/O STRAINER

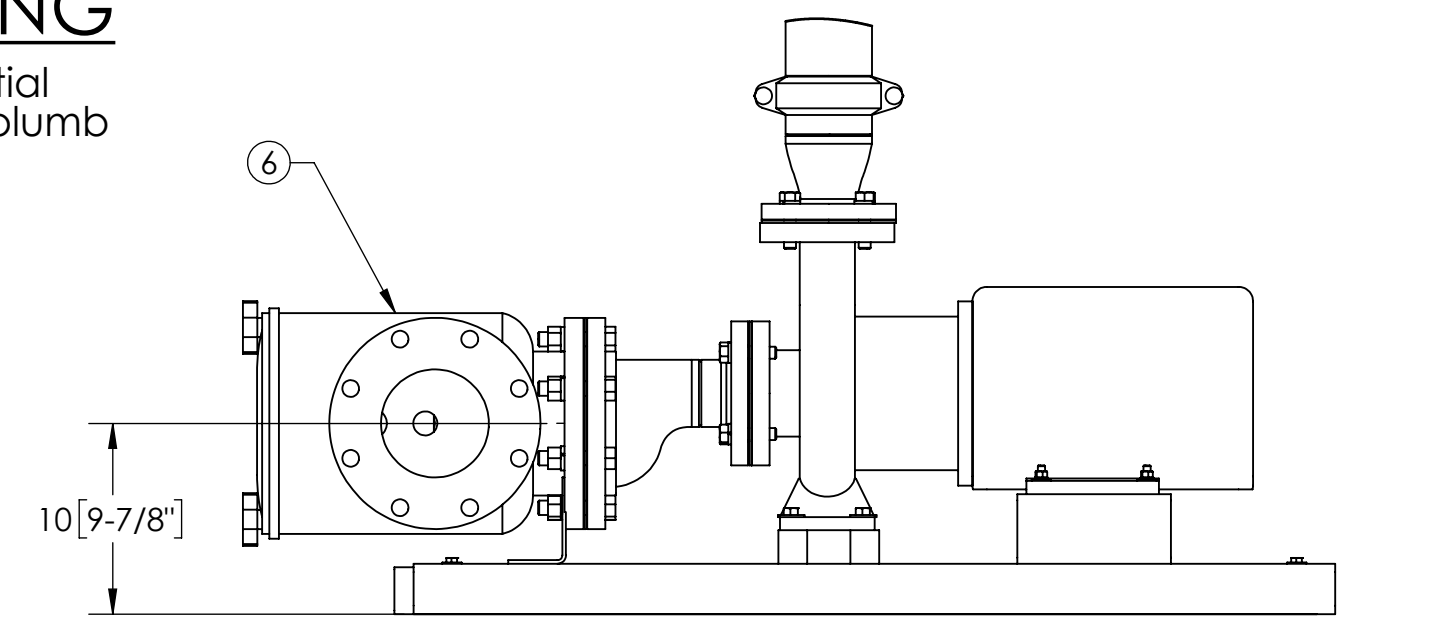

FRONT VIEW ROTATED STRAINER (OPTIONAL)

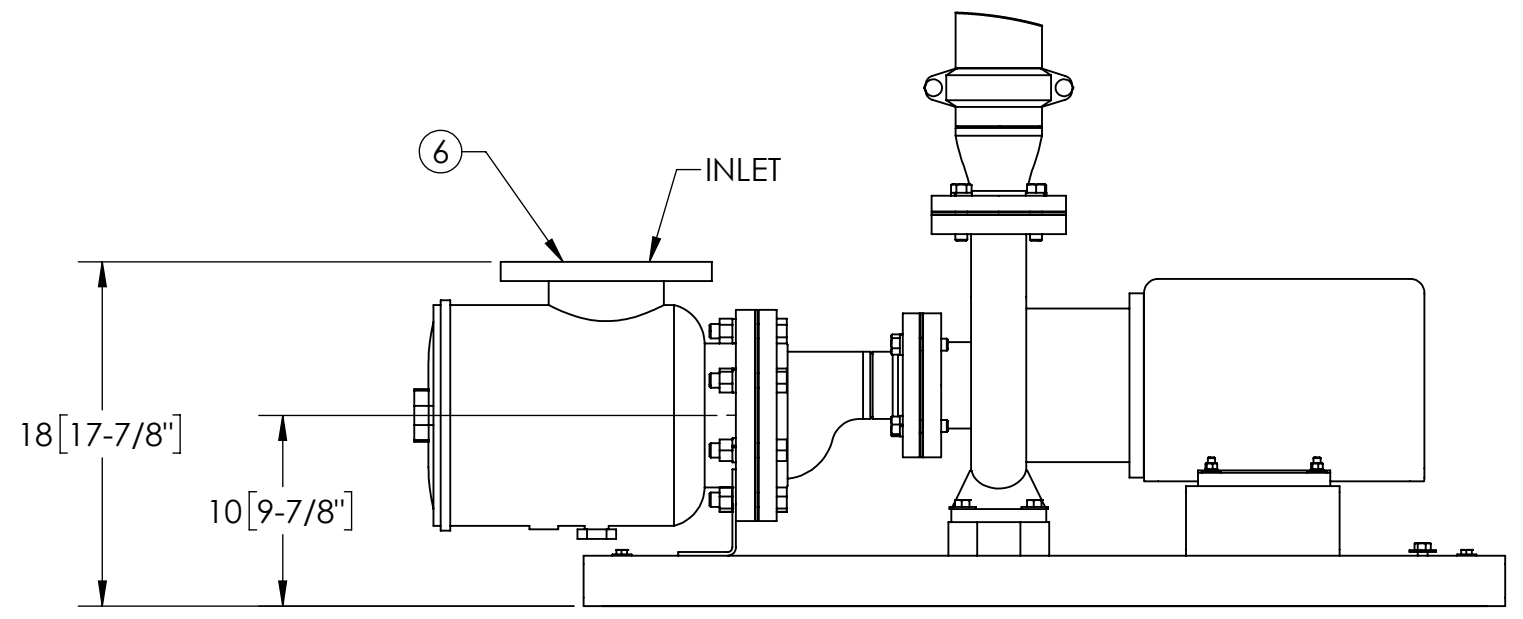

FRONT VIEW PUMP & STRAINER

THIS DRAWING HAS BEEN GENERATED AND IS MAINTAINED BY A CAD SYSTEM. CHANGES SHALL ONLY BE INCORPORATED AS DIRECTED BY AN APPROVED ENGINEERING CHANGE ORDER (ECO). PAPER COPIES ARE UNCONTROLLED.

UNLESS OTHERWISE SPECIFIED: DIMENSIONS ARE IN: INCHES (mm) TOLERANCES ARE:		ENGINEERED FOR: STANDARD		LAKOS		CLAUDE LAVAL CORP. FRESNO, CALIFORNIA 93727 WWW.LAKOS.COM	
DECIMALS	ANGLES	APPROVALS	DATE	TITLE		REV.	
0 ± 0.05	± 1/4°	TRR	12/10/12	eTCX-0310-EFS, TC SYSTEM		E	
DO NOT SCALE DRAWING		ENGR	-	HI EFF SWEEPER eHTX-0140, 3/60/208 230 460V		SCALE	
MATERIAL	FINISH	MFG	WORK ORDER	SIZE	MODEL NO.	DWG NO.	SHEET
PER LAKOS SPEC	AS ASSEMBLED	-	-	C	-	135308	1 OF 1
EST. WT. 1161 kg		SHEET		SCALE 1:10		DWG NO. 135308	

DWG NO. 135308 SHEET REV. E