

EXCEPT AS OTHERWISE PROVIDED BY CONTRACT, THIS DRAWING AND SPECIFICATIONS SHALL NOT BE REPRODUCED, COPIED OR USED AS THE BASIS FOR MANUFACTURE OR SALE OF MATTER DEPICTED HEREIN WITHOUT THE EXPRESSED WRITTEN PERMISSION OF THE CLAUDE LAVAL CORPORATION, OR ITS ASSIGNEES.

OPERATION WEIGHT: APPROX. 902 LB (409 KG)

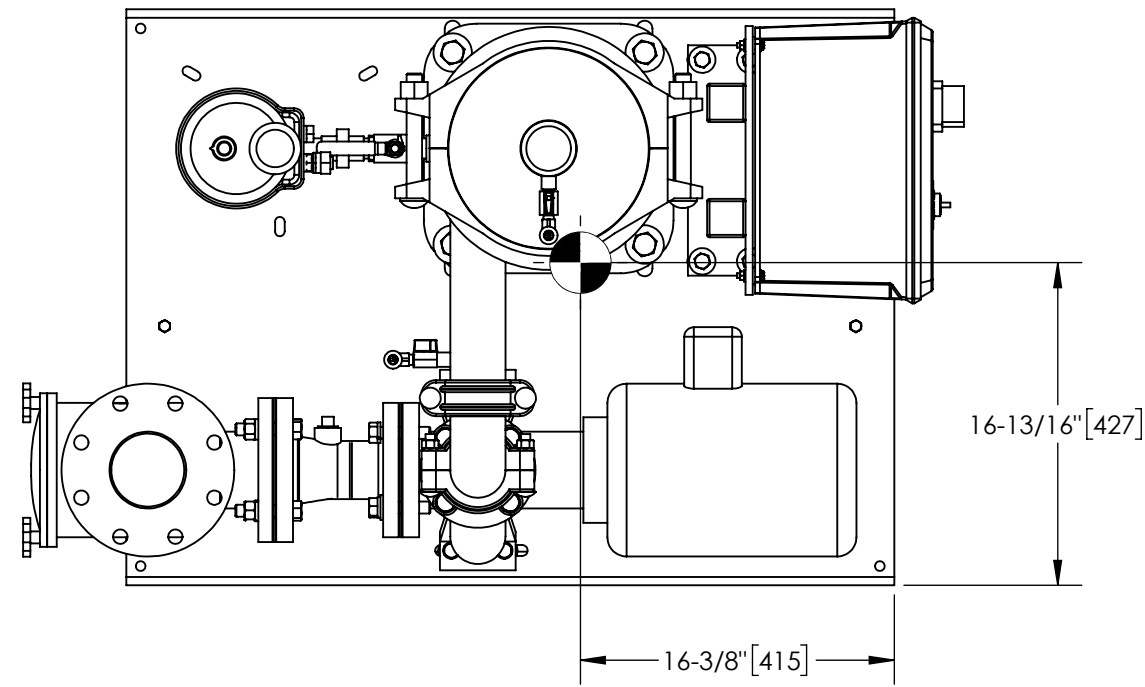

TOP VIEW

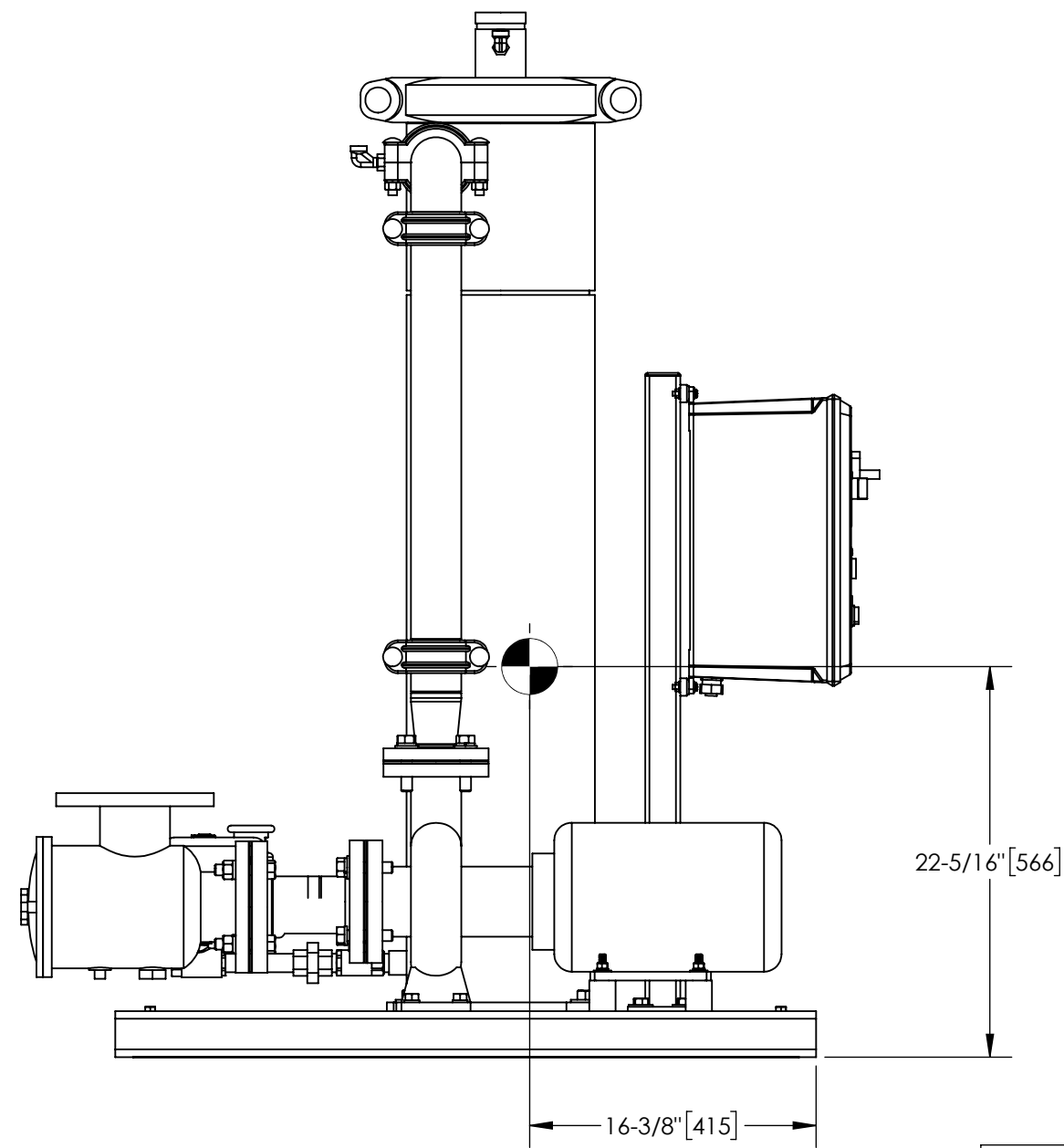

FRONT VIEW

| | | | |
|--|---|-----------------|---------|
| UNLESS OTHERWISE SPECIFIED: DIMENSIONS ARE IN: INCHES (mm) TOLERANCES ARE: | | ENGINEERED FOR: | |
| FRACTIONS | DECIMALS | ANGLES | |
| ± | .XX ± .01 .XXX ± .005 .XXXX ± .0005 | ± 1/4° | |
| DO NOT SCALE DRAWING | | APPROVALS | DATE |
| MATERIAL | | DRAWN | TRR |
| FINISH | | ENGR | 1/11/16 |
| | | MFG | |
| | | WORK ORDER | QTY. |
| | | | |

| | | | |
|---|-----------|---|--------|
| LAKOS | | CLAUDE LAVAL CORP. FRESNO, CALIFORNIA 93727 WWW.LAKOS.COM | |
| TITLE CG DRAWING eTCX-0160-EFS, TC SYSTEM | | | |
| SIZE | MODEL NO. | DWG NO. | REV. |
| C | | 135306 | C |
| SCALE | 1:10 | EST. WT. | 902 lb |
| | | SHEET | 2 OF 2 |

DWG NO. 135306
SHEET C