

EXCEPT AS OTHERWISE PROVIDED BY CONTRACT, THIS DRAWING AND SPECIFICATIONS SHALL NOT BE REPRODUCED, COPIED OR USED AS THE BASIS FOR MANUFACTURE OR SALE OF MATTER DEPICTED HEREIN WITHOUT THE EXPRESSED WRITTEN PERMISSION OF THE CLAUDE LAVAL CORPORATION, OR ITS ASSIGNEES.

NOTES:

1. INLET & OUTLET ARE 3/4" MNPT PIPE.
2. MAXIMUM PRESSURE: 150 psi (10.3 bar).
3. MAXIMUM TEMPERATURE: 180°F (82.2°C).
4. PRESSURE LOSS: 3-12 psid (.2-.8 bar) AT RATED FLOW.
5. RATED FLOW: 10-20 gpm (2.5-4.5 m³/hr).
6. APPROXIMATE DRY WEIGHT: 37 lbs (16.8 kg).
7. FINISH: LAKOS BLUE (EXTERIOR ONLY).

REVISION HISTORY				
ZONE	REV	DESCRIPTION	DATE	APPROVED

THIS DRAWING HAS BEEN GENERATED AND IS MAINTAINED BY A CAD SYSTEM. CHANGES SHALL ONLY BE INCORPORATED AS DIRECTED BY AN APPROVED ENGINEERING CHANGE ORDER (ECO). PAPER COPIES ARE UNCONTROLLED.

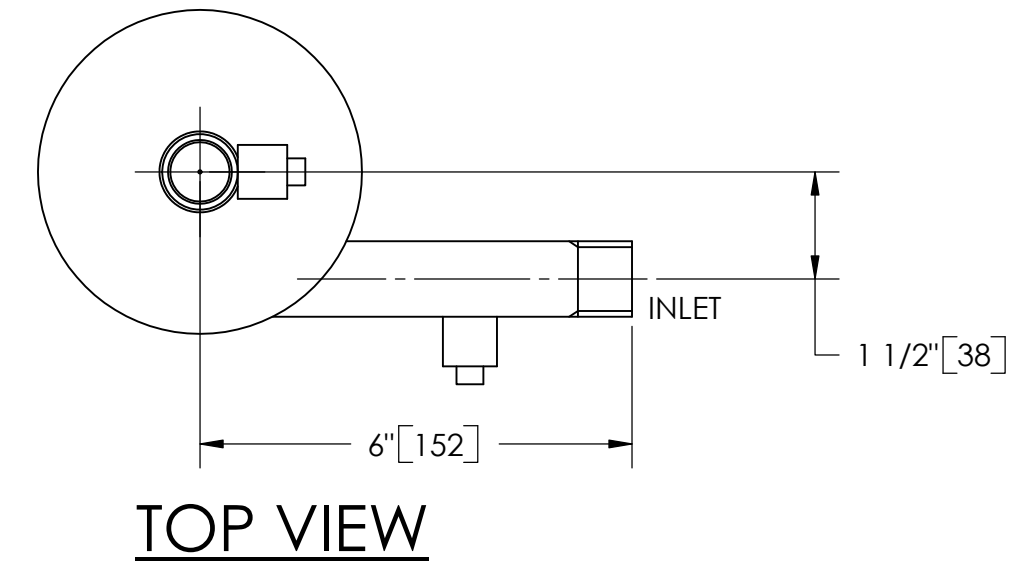
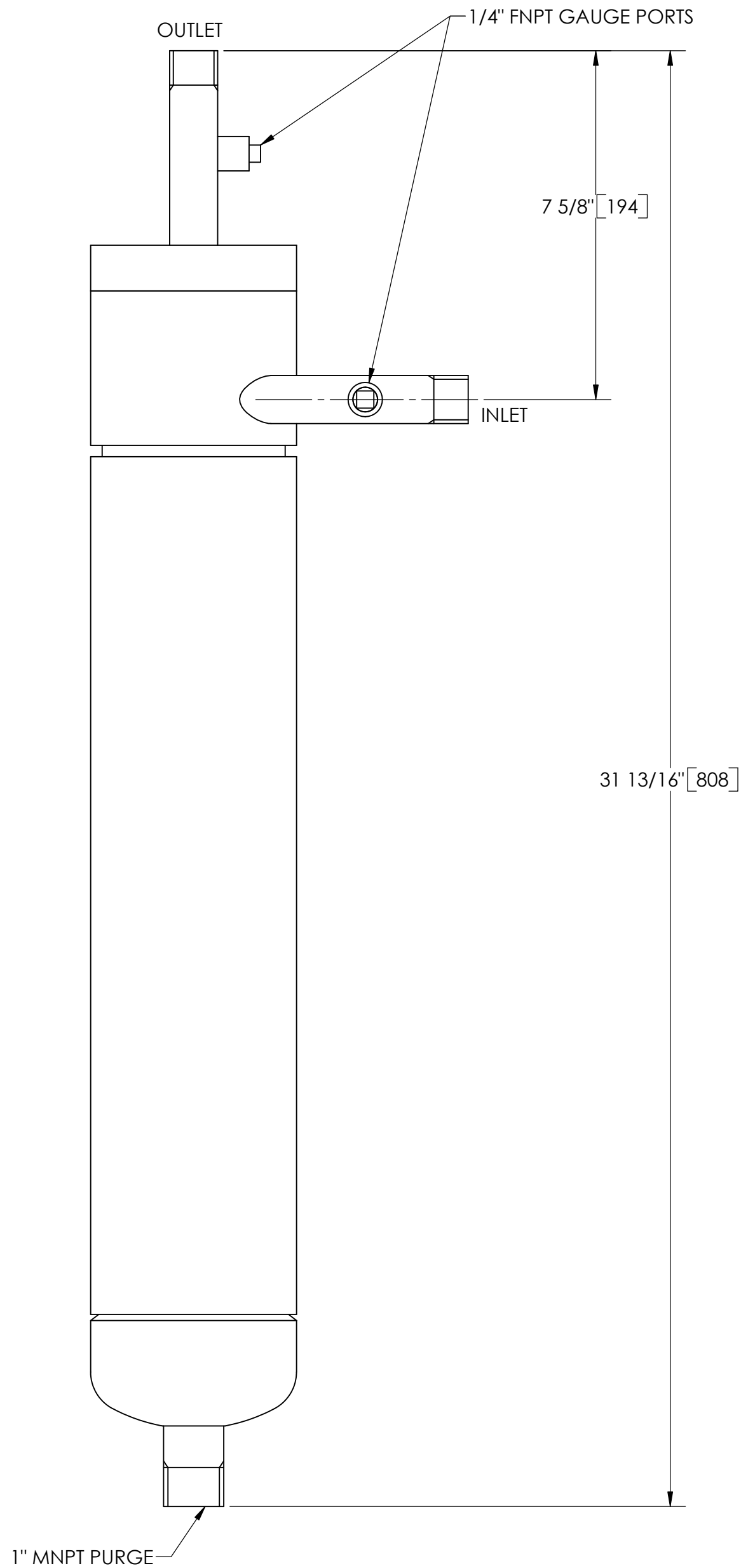

SUBMITTAL DRAWING

This drawing is submitted for spatial consideration only. Do not pre-plumb to these dimensions.

UNLESS OTHERWISE SPECIFIED: DIMENSIONS ARE IN: INCHES [mm] TOLERANCES ARE:		ENGINEERED FOR: STANDARD		CLAUDE LAVAL CORP. FRESNO, CALIFORNIA 93727 WWW.LAKOS.COM		LAVAL UNDERGROUND SURVEYS	
FRACTIONS ± 1/4"	DECIMALS .XX ± .01 .XXX ± .005 .XXXX ± .0005	ANGLES ± 1/4°	APPROVALS	DATE	TITLE JPL-0010, SEPARATOR, 10-20 gpm, CARBON STEEL		
DO NOT SCALE DRAWING			DRAWN DLW	1/16/06	SIZE C		
MATERIAL CLASS P-1 MILD CARBON STEEL			ENGR β	2/3/06	MODEL NO.		
FINISH LAKOS BLUE			MFG -	-	DWG NO. 116529		
			WORK ORDER	QTY.	EST. WT. 37 lb		
					SHEET 1 OF 1		

DWG NO. 116529
SHEET 1
REV. C