

Horizontal Profile HL

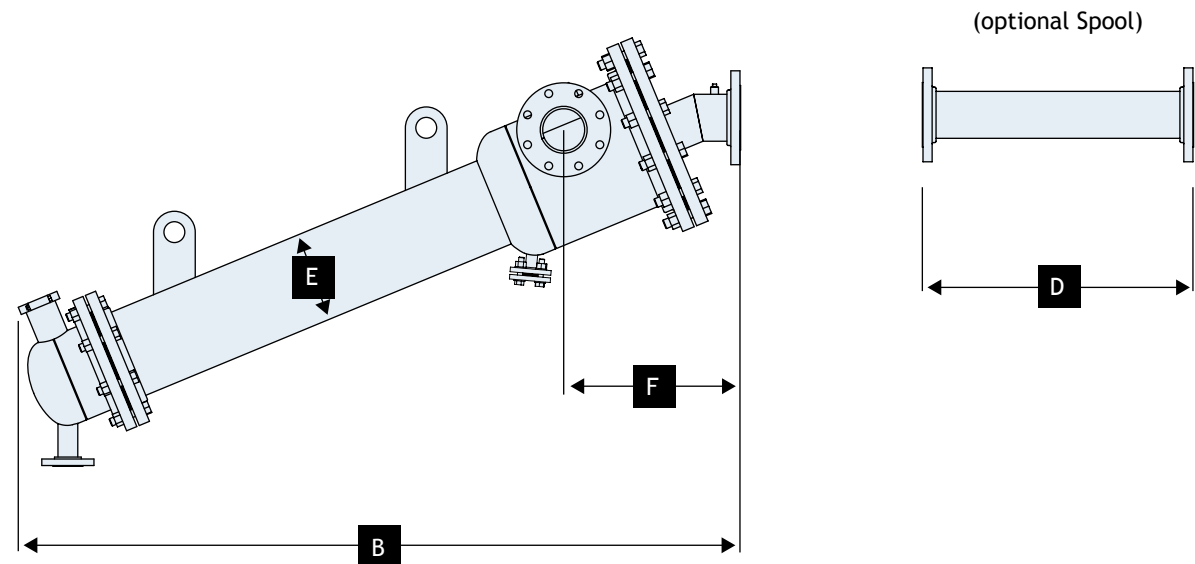
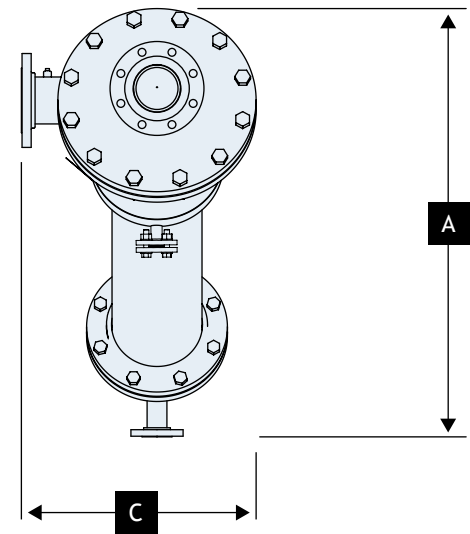

Dimensions

Model	A		B		C		D		E		F	
	in	mm	in	mm	in	mm	in	mm	in	mm	in	mm
CSX-0360-HL	41	1041	69 1/4	1759	22 1/2	572	26	660	8 5/8	219	17	432
CSX-0565-HL	50	1270	86 1/2	2197	25	635	28	711	10 3/4	273	16 9/16	421
CSX-0815-HL	56 5/16	1430	97 5/16	2472	27 1/4	692	28	711	12 3/4	324	19 1/8	486
CSX-1450-HL	66 3/4	1695	119 1/16	3024	31 1/4	794	36	914	16	406	26 3/8	670
CSX-2300-HL	74 1/8	1883	130 1/4	3308	34 1/2	876	38	965	18	457	31 3/4	806

Limited Warranty

All products manufactured and marketed by this corporation are warranted to be free of defects in material or workmanship for a period of at least one year from date of delivery. Extended warranty coverage applies as follows:

All LAKOS Separators: Five year warranty

All other components: 12 months from date of installation; if installed 6 months or more after ship date, warranty shall be a maximum of 18 months from ship date.

If a fault develops, notify us, giving a complete description of the alleged malfunction. Include the model number(s), date of delivery and operating conditions of subject product(s). We will subsequently review this information and, at our option, supply you with either servicing data or shipping instruction and returned materials authorization. Upon prepaid receipt of subject product(s) at the instructed destination, we will then either repair or replace such product(s), at our option, and if determined to be a warranted defect, we will perform such necessary product repairs or replace such product(s) at our expense.

This limited warranty does not cover any products, damages or injuries resulting from misuse, neglect, normal expected wear, chemically-caused corrosion, improper installation or operation contrary to factory recommendation. Nor does it cover equipment that has been modified, tampered with or altered without authorization.

No other extended liabilities are stated or implied and this warranty in no event covers incidental or consequential damages, injuries or costs resulting from any such defective product(s).

Lakos Separators are manufactured and sold under one or more of the following U.S. Patents:

5,320,747; 5,338,341; 5,368,735; 5,425,876; 5,571,416; 5,578,203; 5,622,545; 5,653,874; 5,894,995; 6,090,276; 6,143,175; 6,167,960; 6,202,543; 7,000,782; 7,032,760 and corresponding foreign patents, other U.S. and foreign patents pending.

Testimonials



Top: LAKOS CSX-1450L-S4 (In a FrySafe configuration)

Bottom left: Baskets inside the collection vessel

Bottom right: Purge System showing collection vessels and valves.



CSX-050 HV



One of the largest privately owned snack food vendors in the United States uses a LAKOS CSX-050 HV to ensure the highest quality of potato chip production.

Name withheld upon request – they consider LAKOS a huge competitive advantage.



Return On Investment Example:

Using a LAKOS Separator as an effective filtration method for cooking oil can pay for itself in cost savings in a very short amount of time. A chip processing plant in Ecuador determined that they could extend the effective life of their cooking oil by 50% by using a LAKOS – a savings of over \$85,000 in oil alone per year. Read more about it in Case Study AB-227.

Printed on recycled paper

LS-733C (Rev. 7/17)

Centrifugal Separator Filtration For Cooking Oil Systems

Extended operating cycles between downtime/maintenance, while reducing heat exchanger fouling

CSX
Separators

Exclusive and patented technology continuously removes crumbs and fines from cooking oil to extend oil life and sustain higher product quality. LAKOS CSX Series Separators employ centrifugal action to remove unwanted particle matter from pumped/recirculated cooking oil, concentrating the particulate for easy solids removal. Collection vessels also available from LAKOS.

Benefits of Using CSX Centrifugal Separators

- Full flow filtration of the entire cooking oil reservoir or system.
- Operates in a pressurized, non-oxygenated environment.
- Longer operating cycles between downtime/maintenance.
- Reduced heat exchanger fouling & sustained heat transfer capacity.
- Optimum/consistent cooking oil velocities and the elimination of dead spots within the fryer by the prevention of crumbs and fines accumulation.
- Maximum cooking oil quality, including improved oil appearance and a lighter oil flavor.
- Removing crumbs and fines lowers the rate in which they affect free fatty acids.

For complete, turnkey systems, refer to literature LS-732 for FrySafe Systems.

Flow range:
50 - 6125 US gpm (11 - 1390 m³/hr)
Maximum standard pressure rating:
100 psi (6.8 bar)



LAKOS also provides complete packaged solutions for maximum efficiency and safety. See literature LS-732 for FrySafe Systems. Consult factory for options.



LAKOS
A LINDSAY COMPANY

1365 North Clovis Avenue • Fresno, California 93727 USA
Telephone: (559) 255-1601
www.lakos.com • info@lakos.com

LAKOS
A LINDSAY COMPANY

How It Works

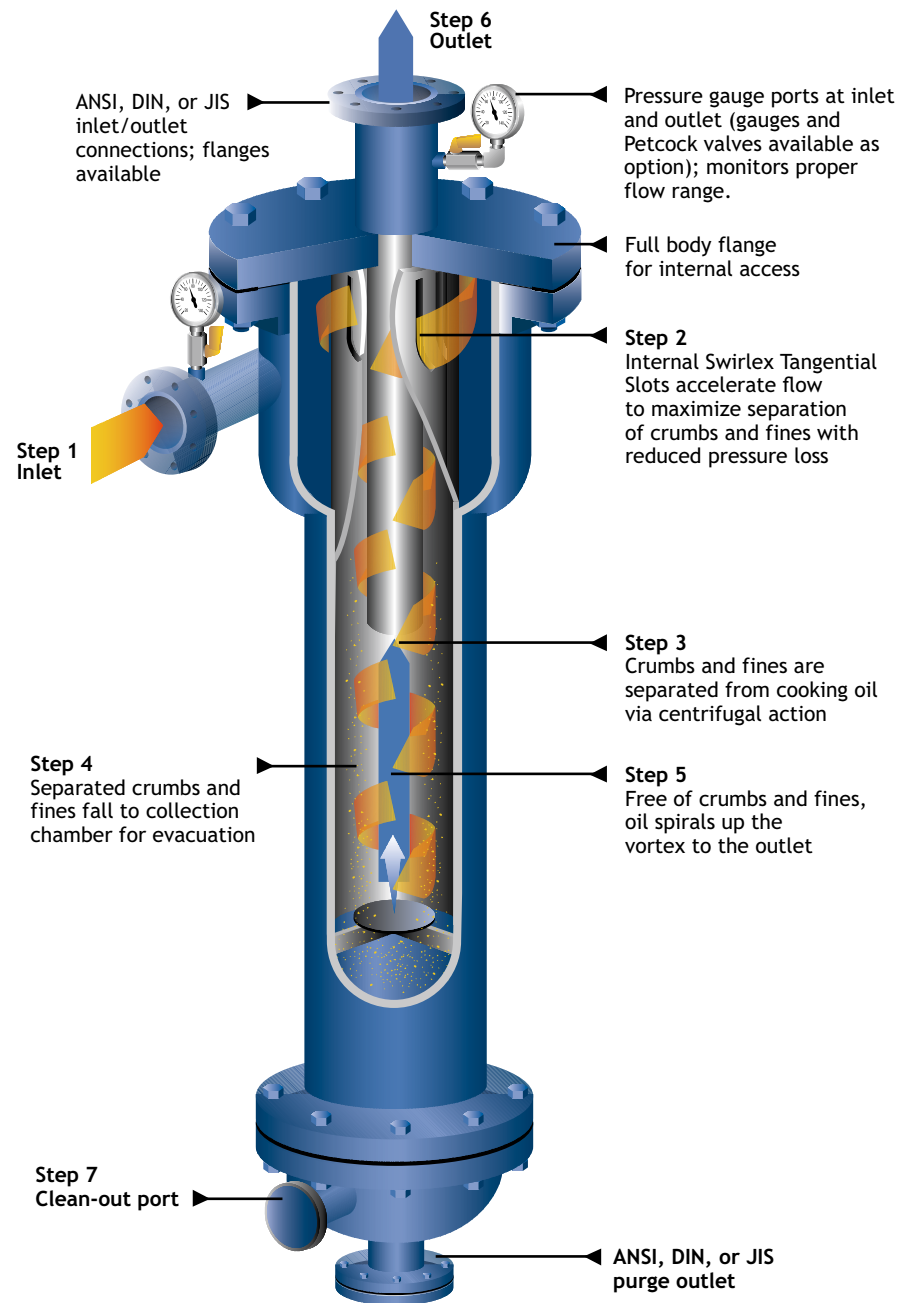

Other Key Features

- No moving parts to wear out
- Low and steady pressure loss, independent of separated crumbs and fines accumulation
- Compact, space saving profile
- Minimal oil loss
- Effective crumbs and fines concentration for easy collection
- Stainless steel (other materials available on request) construction & high temperature componentry
- Pressure rated to 100 psi (6.8 bar); higher pressures also available
- Flanged, inlet, outlet and purge connections
- Full internal accessibility for cleaning/serviceability
- CSX Separators are available as complete packaged systems. See LAKOS FrySafe System literature LS-732 for more information.

Standard Equipment

- Centrifugal Separator

Optional Accessories

- Collection Vessel
- Pressure Gauge
- Petcock Valve
- Flange Options
- For a complete system solution, refer to the FrySafe System in LS-732.

Model Specifications

Model	Flow Range (Cooking Oil Only)		Inlet/Outlet Size *ANSI Flange	Inside Oil Capacity		Dry Weight	
	U.S. gpm	m ³ /hr		U.S. gal.	liters	lbs	kg
CSX-0050	50-80	12-18	1-1/2-inch	2.7	10.2	148	67
CSX-0075	75-125	17-29	2-inch	6.0	22.7	226	103
CSX-0110	110-180	25-40	2-1/2-inch	7.7	29.2	245	111
CSX-0165	165-280	38-65	3-inch	8.0	30.3	274	124
CSX-0250	250-400	57-90	4-inch	16.7	63.2	490	222
CSX-0360	360-670	82-152	4-inch	21.5	81.4	498	226
CSX-0565	565-1030	130-235	6-inch	34.0	128.7	498	226
CSX-0815	815-1500	185-340	6-inch	54.0	204.4	801	363
CSX-1450	1450-2700	330-615	8-inch	107.0	405.0	816	370
CSX-2300	2300-4250	525-965	10-inch	146.0	552.6	1305	592
CSX-3300	3300-6125	750-1390	12-inch	217.0	820.0	2389	1084

Material construction: Available in carbon steel and 304L or 316L stainless steel. Electro-polishing of interior/exterior also available.

*Connections: Inlet, outlet and purge are each standard ANSI, DIN, JIS flanges. DIN and JIS dimensions are slightly different than those shown. Contact LAKOS for more information. Sanitary connections also available. Purge may also be specified as NPT male.

Optional legs can be provided

Standard Temperature Rating: 400°F (204°C)

Standard Pressure Rating: 100 psi (6.8 bar)

Max Particle Size: 3/8" (9.5 mm)

NOTE: Certain caustic washing may degrade the integrity of carbon steel tanks, pumps, and centrifugal separators. We recommend only stainless steel products in these applications.

Typical Application Diagram

Crumbs and Fines Collection Option
The continuous purging of crumbs and fines into a specialized collection vessel concentrates the solids for easy handling, returning all cooking oil to the process.

*A bypass line may need to be added to prevent clogging.

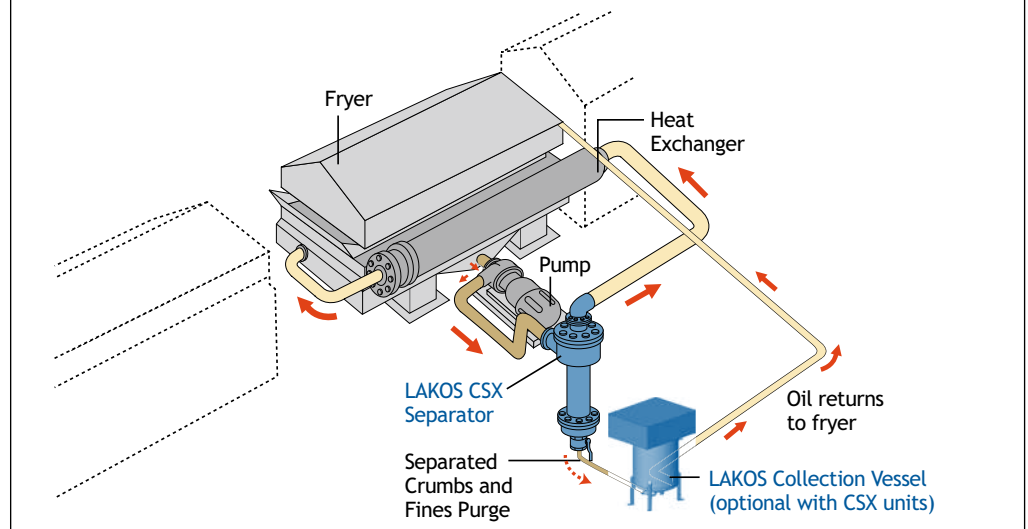

Application Photos



CSX-0050 HV



CSX-1450HL



Collection Vessel (optional equipment)



Vertical Profile HV

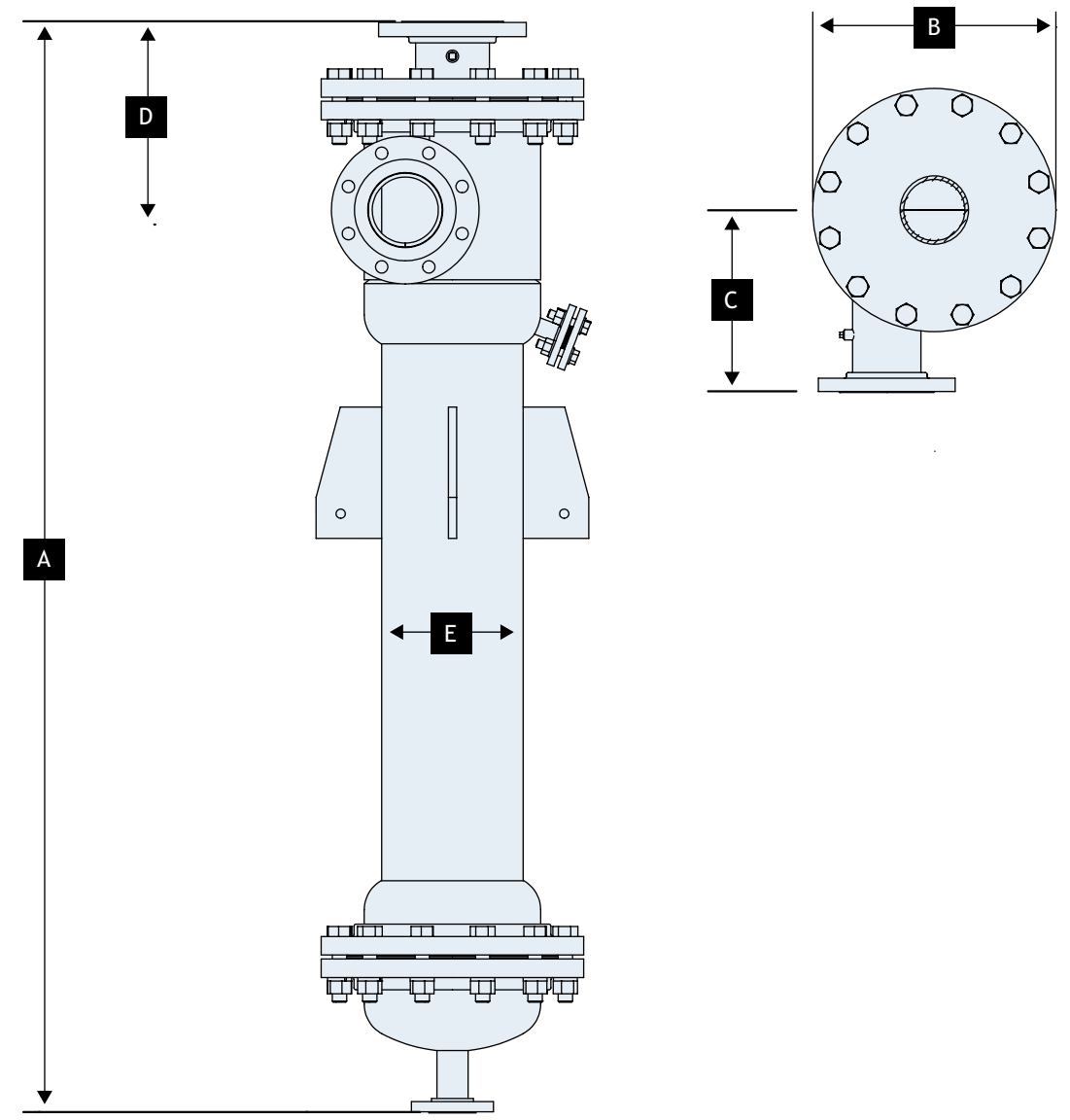

Dimensions

Model	A		B		C		D		E	
	in	mm	in	mm	in	mm	in	mm	in	mm
CSX-0050-HV	34 13/16	884	11	279	8 1/2	216	8	203	4	102
CSX-0075-HV	47 1/4	1200	13 1/2	343	9 1/2	241	10 3/4	273	5 9/16	141
CSX-0110-HV	51	1295	13 1/2	343	9 1/2	241	9	229	6 5/8	168
CSX-0165-HV	54 1/16	1373	13 1/2	343	10	254	10 3/4	273	6 5/8	168
CSX-0250-HV	66 1/2	1689	16	406	11 1/2	292	11 1/2	292	8 5/8	219
CSX-0360-HV	75 3/8	1915	19	483	13	330	14 3/4	375	8 5/8	219
CSX-0565-HV	94 3/8	2397	21	533	14 1/2	368	14 5/16	364	10 3/4	273
CSX-0815-HV	105 5/8	2683	23 1/2	597	15 1/2	394	16 11/16	424	12 3/4	324
CSX-1450-HV	125 5/8	3191	27 1/2	699	17 1/2	445	20 5/16	516	16	406
CSX-2300-HV	137 5/16	3488	32	813	18 1/2	470	25 1/8	638	18	457